

METRA[™] SCAN 3D

THE OPTICAL CMM
3D SCANNERS FOR
INDUSTRIAL APPLICATIONS

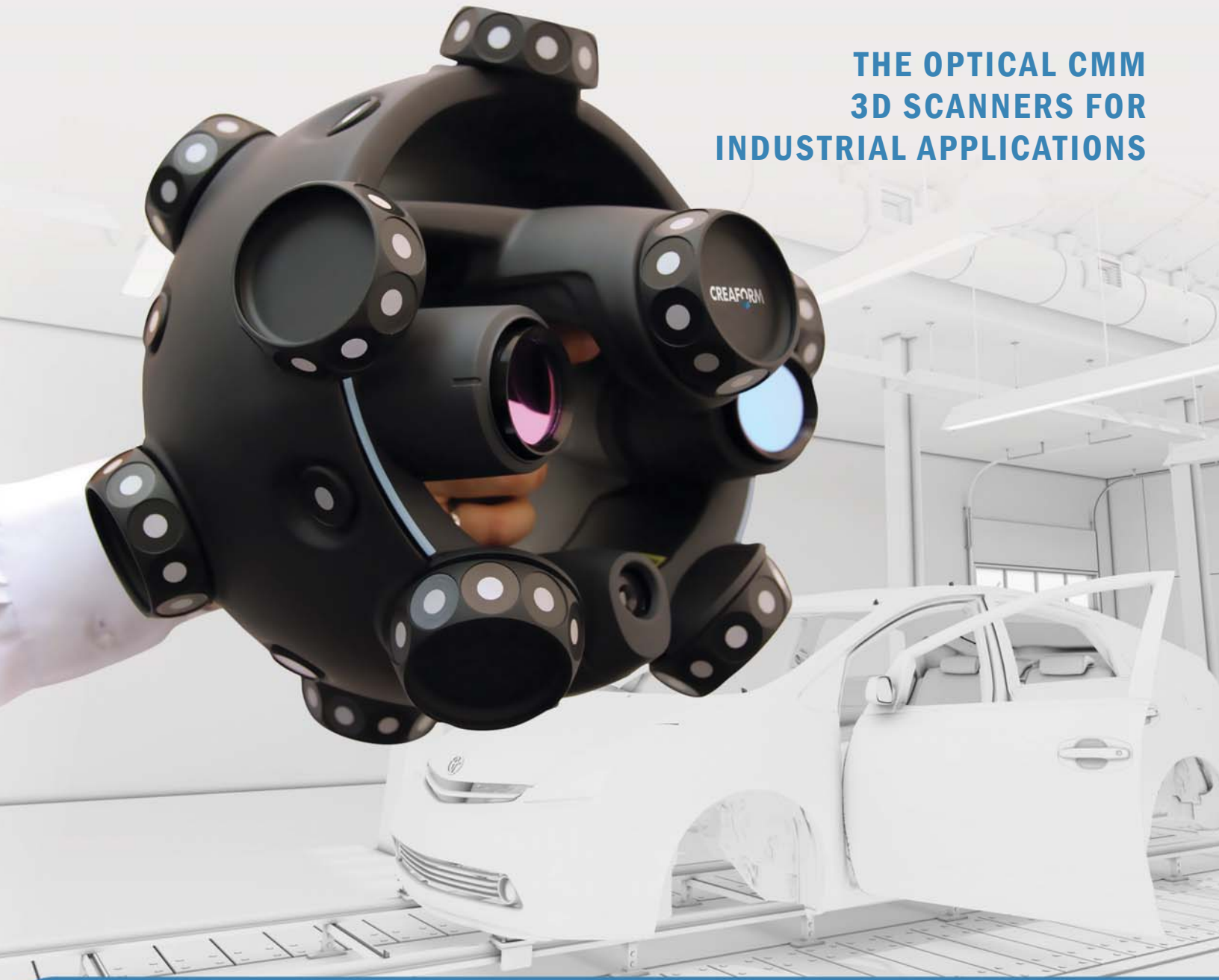

On the shop floor, the MetraSCAN 3D outperforms scanners that are mounted on traditional portable CMMs. Because it is truly portable and insensitive to changes in the environment (e.g. part displacement, set-up or CMM instability), it is highly efficient at measuring parts that can't be moved to a granite or cast iron table. Combined to the HandyPROBE CMM (included), the MetraSCAN 3D is the best solution for geometric and surface inspection on parts ranging from 1 to 10 meters in size, no matter the type of material they are made of.

The MetraSCAN 3D is currently used on the production lines of major players from the automotive, aerospace and manufacturing industries.



GREATER, EXTENDABLE MEASUREMENT VOLUME.

CAN BE EASILY AND DYNAMICALLY EXTENDED **WITHOUT ANY LOSS OF ACCURACY** AND WITHOUT **ANY CONVENTIONAL LEAPFROG**

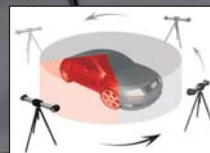

AUTOMATIC ALIGNMENT. THE USE OF OPTICAL REFLECTORS ALLOWS SCANNING AND PROBING OF MANY IDENTICAL PARTS IN RAPID SUCCESSION



NO NEED FOR THE OPERATOR TO RE-ALIGN DATA AFTER MOVING THE PART OR THE C-Track, RESULTING IN **LESS SET-UP AND ERROR ACCUMULATION**

MEASUREMENT OF PARTS IN PRODUCTION WITHOUT HAVING TO ALIGN EVERY PART

COMPLETE AND POWERFUL INSPECTION SOLUTION.

ALLOWS GEOMETRICAL AND FREEFORM INSPECTION OR REVERSE ENGINEERING COMBINING PROBING AND SCANNING ON THE SAME SYSTEM

SCANNING AND PROBING SOLUTION FOR **GEOMETRIC/SURFACE INSPECTION**

PARTS RANGING FROM **1-10 m**, MADE OF **ANY TYPE** OF MATERIAL

TRUsimplicity™

FASTER AND EASIER MEASUREMENT.

HANDHELD AND ARM-FREE. ALLOWS THE USER TO MOVE FREELY AROUND THE PART

USER-FRIENDLY. INTUITIVE SYSTEM WITH A VERY SHORT LEARNING CURVE

5-MINUTE INSTALLATION.

TRUaccuracy™ TECHNOLOGY.

HIGHLY-ACCURATE MEASUREMENTS, **NO MATTER** THE MEASUREMENT **ENVIRONMENT** (INSTABILITY, VIBRATIONS, THERMAL VARIATIONS, ETC.) **OR OPERATOR SKILLS.**



COMPATIBLE WITH ALL MAJOR SOFTWARE. INSTANT INTEGRATION INTO YOUR QC PROCESS

TRUportability™

TRULY PORTABLE. INSPECTION OR REVERSE ENGINEERING OF PARTS, SUB-UNITS OR COMPLEX ASSEMBLIES WITH UNEQUALLED PRECISION, MOBILITY AND FLEXIBILITY - NO MATTER WHERE (LAB, FACTORY, OFF-SITE).



TRUaccuracy™ TECHNOLOGY

The Most Accurate Measurement Solution.

Creaform's TRUaccuracy™ technology ensures highly-accurate measurements, regardless of the measurement environment (instability, vibrations, thermal variations, etc.) or operator skills.

- With the **dynamic referencing** mode of the C-Track, the coordinate system can be literally "locked" onto the part(s) being measured, thus maintaining part alignment during the entire 3D scanning process.
- With the **automatic alignment** function, manual operation is no longer needed during the alignment phase and root cause errors are drastically reduced.
- With the fast user calibration process using a certified gauge, the MetraSCAN 3D optical CMM scanners deliver constant accuracy during its entire life cycle.
- With **the continuous monitoring of parameters** (temperature, accuracy, etc.), device accuracy is maintained throughout entire operation.

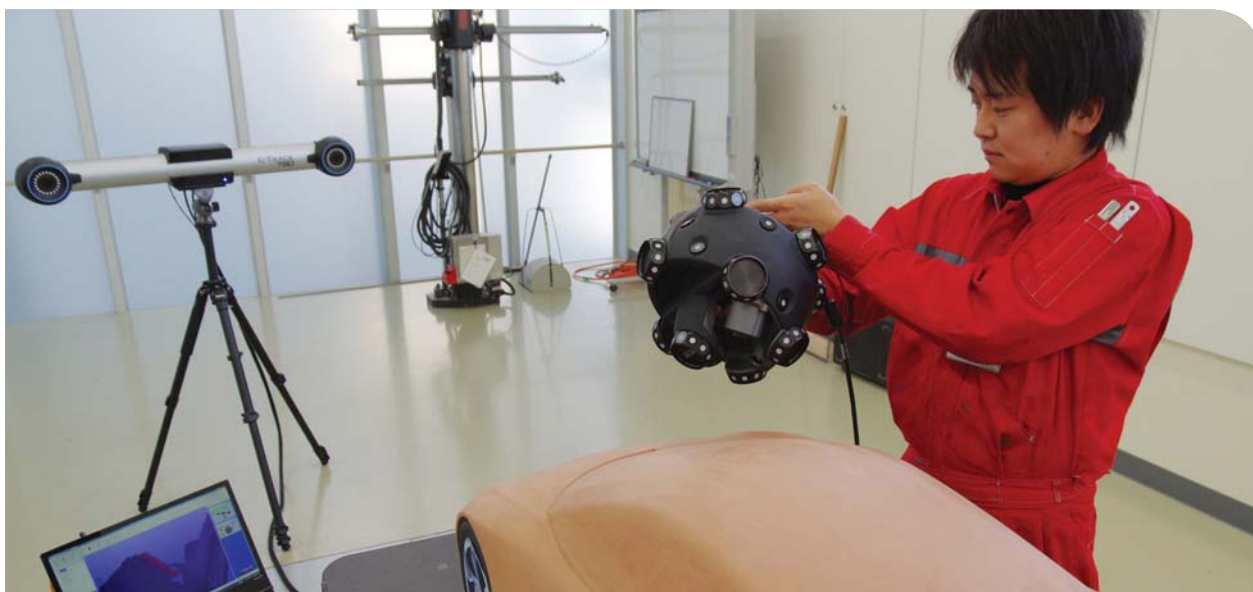
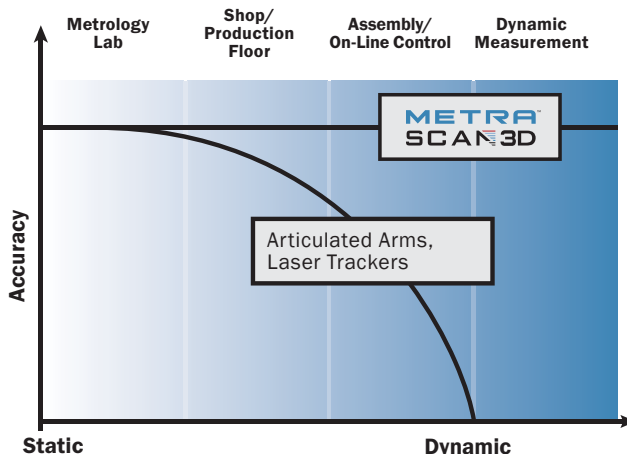

APPLICATIONS

The MetraSCAN 3D scanner is especially useful for customers who are looking for a portable 3D measurement solution to measure length, geometric entities or surfaces. The MetraSCAN 3D works directly on the shop floor, without granite or steel tables or dedicated control jigs.

The 3D measurement device reaches a measurement accuracy of 0.085 mm on parts of size ranging from 1 to 3 meters, with possible extension of up to 10 m, and made of any type of hard material.

MetraSCAN 70

The MetraSCAN 70 offers increased resolution. It is ideal for projects where geometrical feature definition is key, such as sheet metal and tooling inspection.

MetraSCAN 210

Because it features extended scanning surface, the MetraSCAN 210 offers increased measurement speed with equal accuracy. Its increased stand-off and depth of field make for enhanced scanning flexibility. It is ideal for large surface metrology and large-scale reverse engineering.

The MetraSCAN 3D optical CMM scanners can carry out the following tasks:

Inspection and QC

- Part-to-CAD analysis
- First article inspection
- Supplier product quality inspection
- Conformity assessment of 3D models against original parts or production tooling
- Conformity assessment of manufactured parts against originals
- Alignment
- Tooling certification

Reverse Engineering

- 3D scan-to-CAD
- 3D modeling
- Tooling and jigs development
- Maintenance, repair and overhaul (MRO)
- Finite Element Analysis (FEA)

THE C-Track™ DUAL-CAMERA SENSORS

The C-Track dual-camera sensors are fitted with high quality optics and special lighting, enabling them to measure all reflectors within their operating space. In addition to tracking the whole system's reference model, the C-Tracks ensure the exact localization of the HandyPROBE, perform continuous image acquisition and transmission, lighting of reflectors, management of the exchanges with the computer and storage of the sensor parameters.



C-Track 780

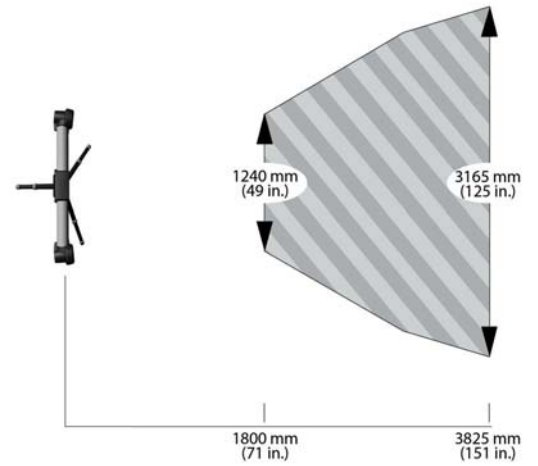

C-Track 780

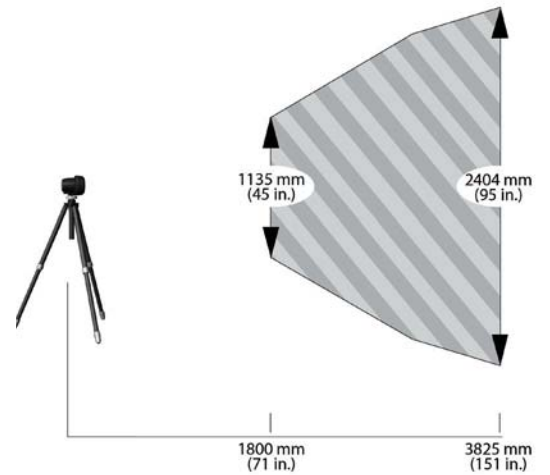

THE HandyPROBE PORTABLE CMM



The HandyPROBE portable CMM arm-free probing system generates high-accuracy measurements (up to 25 μm) and increases the reliability and speed of the measurement process. This portable CMM was designed and optimized to operate in "real-life" shop floor conditions.



C-Track 780





VXelements™

The MetraSCAN 3D optical CMM scanning systems come with VXelements, the all-in-one 3D data acquisition software that powers its entire fleet of 3D scanning and measurement technologies. The software gathers all the essential elements and tools into a uniform, user-friendly and intuitive working environment.

VXscan is entirely dedicated to the acquisition and optimization of 3D scanning data. It delivers high performance for that specific task, yet it is simple and user-friendly enough to suit any user's experience level. The VXscan module allows users to interact with data acquired using MetraSCAN 3D and share it with any other VXelements component or third-party software.

VXelements is now compatible with your tablet and intelligent phone! No matter where you are, you can remotely interact with VXelements and have all its data acquisition functionalities at your fingertips. This is freedom at its best!

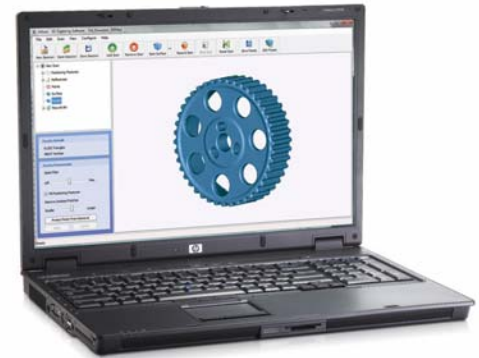

ACCESSORIES

Included

- MetraSCAN 3D scanner
- Ergonomic support
- Recalibration sphere
- FireWire cable
- Carrying case
- VXelements software
- One-year warranty on parts and labour



CREAFORM CUSTOMER SERVICE



When you purchase a MetraSCAN 3D optical CMM scanner, Creaform backs you up with the CreaCare customer service program. We offer readily available, multilingual technical support on all continents, ensured by knowledgeable, proactive and committed product specialists.

We find it important to help you simplify your work, increase your efficiency and make the most out of your MetraSCAN 3D scanner. To keep you on the technological edge, you can also choose to get instant downloading access to every new release of VXelements (and the VXscan module). If you wish, you can ask that a qualified metrologist or applications engineer comes over to your place to help you get started with your optical CMM scanner, and to train you and/or your staff on your specific applications.

Last but not least, Creaform's client service agents follow up with each and every client to make sure that they are satisfied with their MetraSCAN 3D, and that they know exactly who to contact in case of a problem. And if anything should happen, we guarantee quick and reliable servicing.

MetraSCAN 3D

RELATED PRODUCTS

MaxSHOT 3D™

The MaxSHOT 3D optical coordinate measuring system is a complementary product that adds photogrammetry to the range of 3D scanning and probing applications possible with our technologies. The system combines the MaxSHOT 3D photogrammetric video camera and the VXshot™ processing software, and stands out from other systems because it is so easy to use. Its user-friendly design allows even those new to photogrammetry to quickly and easily generate a high accuracy positioning model of an object based on a series of photos.

The MaxSHOT 3D system generates positioning models that can be used with the MetraSCAN 3D to determine their repositioning around the object to be scanned or probed. Doing so, we get highly accurate data, and most especially when measuring larger parts.



C-Link™

The MetraSCAN 70 and the MetraSCAN 210 scanners work with the C-Track dual-camera sensor. It is also possible to network either one of the CMM scanners with 2 or 4 C-Tracks to get access to and benefit from the C-Link functionality, which drastically increases the measurement speed and ease-of-use of the system.



COMPATIBLE SOFTWARE

- 3D Systems (Geomagic® Solutions)
- InnovMetric Software (PolyWorks)
- Dassault (CATIA V5, SolidWorks)
- Delcam (PowerINSPECT)
- Metrologic (Metrolog X4, V5)
- BuildIT Software & Solutions (BuildIT)
- PTC (Pro/ENGINEER)
- Siemens (NX and Solid Edge)
- Autodesk (Inventor, Alias, 3ds Max, Maya, Softimage)

Other software platforms: contact our specialists at info@creaform3d.com.



TECHNICAL SPECIFICATIONS	MetraSCAN 70	MetraSCAN 210
WEIGHT	1.81 kg (4 lbs.)	
DIMENSIONS	282 x 250 x 282 mm (11 x 9.8 x 11 in.)	
MEASUREMENT RATE	36,000 measures /sec.	
LASER CLASS	II (eye-safe)	
VOLUMETRIC ACCURACY (with C-Track 780) ⁽¹⁾	0.085 mm (0.003 in.)	
VOLUMETRIC ACCURACY (with MaxSHOT 3D or C-Link)	0.085 mm if L ⁽²⁾ ≤ 1.2 m (0.0033 in. if L* ≤ 4 ft)	
	0.055 mm + 0.025 mm/m if L > 1.2 m (0.0022 in. + 0.0003 in./ft if L > 4 ft)	
RESOLUTION	0.05 mm (0.002 in.)	0.1 mm (0.004 in.)
STAND-OFF DISTANCE	152 mm (6 in.)	300 mm (12 in.)
DEPTH-OF-FIELD	± 50 mm	± 100 mm
LASER CROSS AREA	70 mm x 70 mm (2.7 x 2.7 in.)	210 mm x 210 mm (8.2 x 8.2 in.)
OPERATING TEMPERATURE RANGE	15-40 °C (59-104 °F)	
OPERATING HUMIDITY RANGE (NON-CONDENSING)	10-90%	
CERTIFICATIONS	EN 301 489-1, EN 301 489-3, EN 300 220-1	

⁽¹⁾ Test methods based on the ASME B89.4.22 standard. Volumetric performance is assessed with traceable length artifacts by measuring these at different locations and orientations within the working volume of the MetraSCAN 3D (range/2 methods).

⁽²⁾ "L" being the size of the object measured.



Head Office
 5825, rue Saint-Georges
 Lévis (Québec) G6V 4L2 Canada
 T. 1 418 833.4446 | F. 1 418 833.9588

info@creaform3d.com | www.creaform3d.com



Authorized Distributor